

THERE ARE TWO **clear** CHOICES

Clear Rolling Shutters

Transparoll Security Shutters

Premium. Elegant. Protection.

Transparoll shutters are the premier security and partition shutters in the StoreSafe family. Transparoll is essentially a "glass" wall that allows for maximum visibility, protection, and elegance. The clear polycarbonate is 250 times stronger than glass of the same thickness. Transparoll shutters roll up when not in use. Transparoll shutters offer security without altering the aesthetic of the shopping environment. Perfect as a security partition or wall, Transparoll can be used for inside or outside applications. StoreSafe Transparoll shutters are the ultimate in vision security.



- The ultimate in security
- Highest visibility
- Reduce energy costs
- Prevent break-ins
- Protect against extreme weather
- Smallest roll up coil available
- Scratch resistant

LX-6 Security Shutters

Elegant Design. Strong. Protection.

Also fabricated with clear polycarbonate pieces, the LX6 rolling shutter is a lighter weight and medium-duty shutter with excellent visibility. The LX6 is similar to the Transparoll, but with three foot wide sections of polycarbonate joined with a vertical spacer to make up the full shutter width. The lighter weight of the LX6 allows for the push-up/pull-down manual operation on shutters up to 100 sq ft.



Shown above, the side rails and box housings match the existing storefront (QMI bronze 06).

Transparoll Security Shutters



Transparoll security shutters prevent theft while providing maximum visibility. Transparoll shutters are covered in a scratch resistant coating, which allows for graffiti to be removed easily. In addition, Transparoll is UV-resistant, preventing discoloration and ensuring the shutter maintains its clarity. The Transparoll shutter is made of 6mm thick polycarbonate, which has a smooth surface, leaving potential intruders with no grip. Transparoll is available in widths up to 18ft. in one piece. Transparoll shutters are installed using solid guides that cannot be broken.



Emergency Release Devices (ERD) and battery backup operation are available.

LX-6 Security Shutters

- Anodized "silver" aluminum horizontal ribs
- QMI standard 7 colors available for box housing, side rails, and bottom slat
- Most sizes available with tubular motor operation keeping box housing size smaller
- Excellent visibility



For both interior and exterior use, the LX6 rolling shutter provides a physical security barrier without compromising the aesthetic. Useful at restaurant patios for patron comfort, or to keep burglars from even attempting a break-in, the QMI LX6 clear shutter system provides convenient protection.



LX6 uses standard housing motors up to 140 sq. ft. Large shutter shown above uses an external motor mounted above the finished ceiling.

PROTECTION **with** **VISION**

Vision Shutter Comparison Chart

QMI StoreSafe Vision Model	Cost factor	Max size spring assist push up/pull down	Max size tube motor w/ std housing	External jack shaft motor required (no housing available)	3x3 or 4x4 steel post required
Transparoll	*****	n/a	n/a	all up to 200 sq ft	yes
LX6	**	100 sq ft	140 sq ft	141 to 280 sq ft	w/ ext motor
AL7-Perforated slat	*	160 sq ft	170 sq ft	171 to 300 sq ft	w/ ext motor

QMI StoreSafe Vision Model	Side rail size	Max width	Max height	Security level	Polycarbonate slat thickness	Hurricane rated	Vision
Transparoll	3.25"w x 2.25"d + angle	18'	14'	high	.25"	no	excellent
LX6	3.5"w x 1.06"d	24'	15'	medium	.093"	no	very good
AL7-Perforated slat	3.375"w x 1.06"d	30'	15'	high	punch aluminum	solid only	good

note: sq ft sizes shown for estimating only. Actual widths and heights will determine actual mounting/control requirements

Transparoll Security Shutters



LX-6 Security Shutters



PROTECTION with VISION

External Motor *typical*

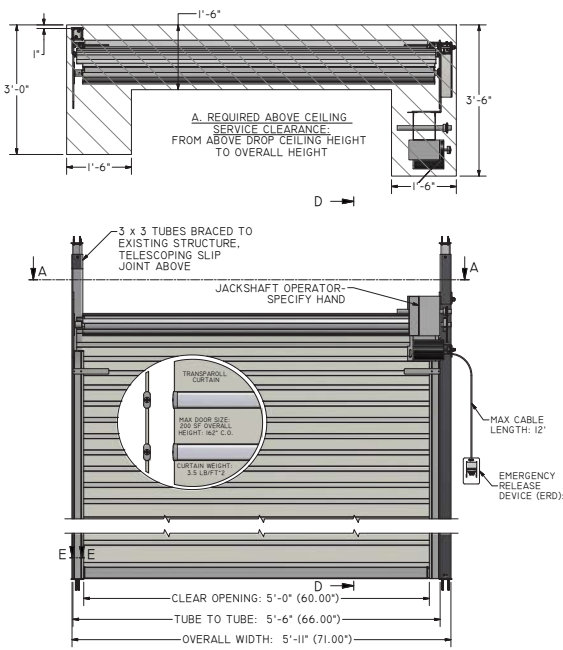

Tube Motor *typical*

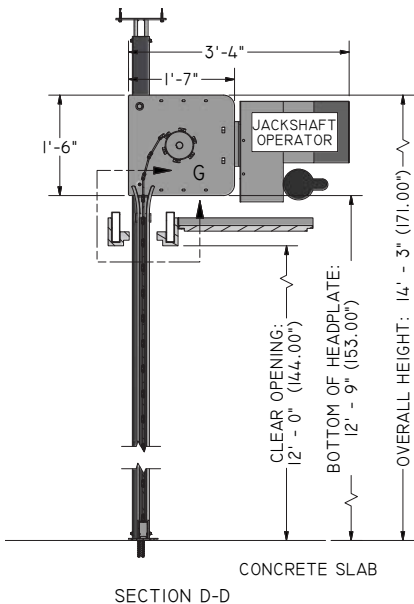
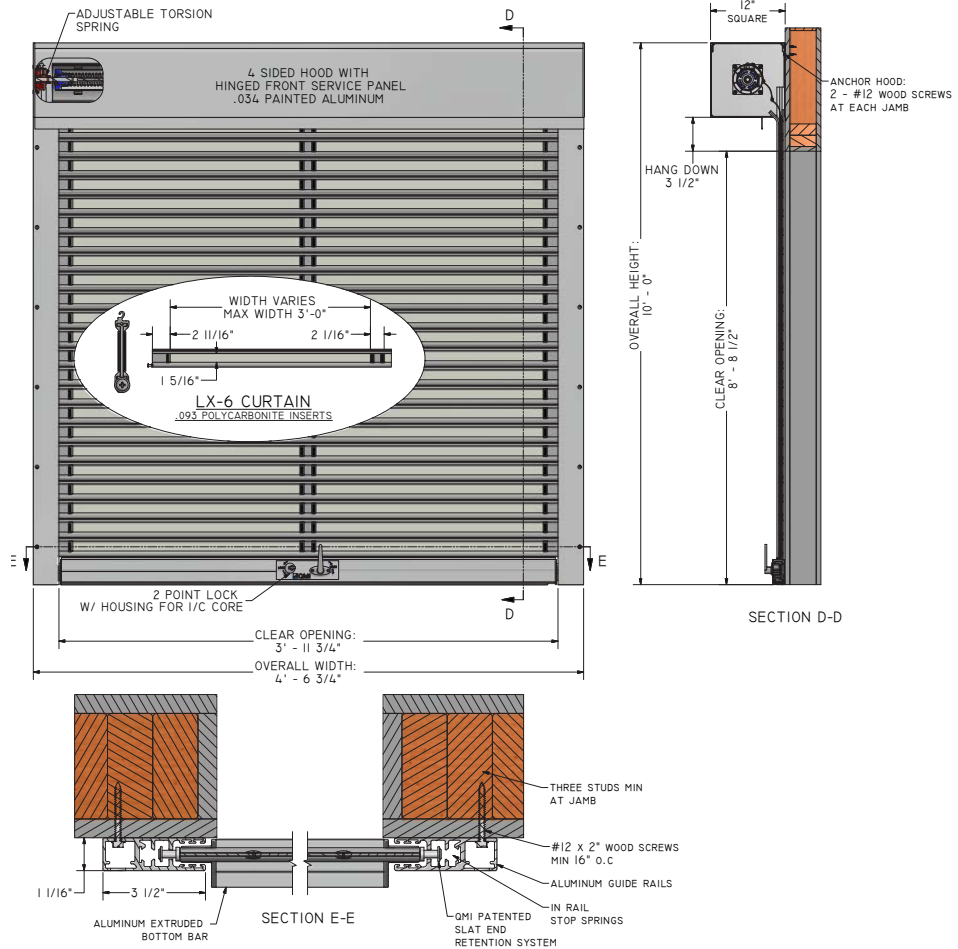

QMI Security Solutions

1661 GLENLAKE AVE • ITASCA, IL. 60143

(800) 446-2500

International: 00 1 630 529 7111

www.qmiusa.com

Copyright© 2015 QMI Security Solutions, Inc. StoreSafe® is a registered brand of QMI. Not to be duplicated, altered or reproduced. To meet building codes listed, specific mounting provisions may be required.

QMI Clear-V3-250