

QMI

STORMSAFE SCREEN - FIXED IMPACT SCREEN - NON-HVHZ

INSTALLATION AND ANCHORAGE DETAILS

GENERAL NOTES:

1. THIS PRODUCT IS DESIGNED TO COMPLY WITH THE CURRENT EDITION OF THE FLORIDA BUILDING CODE (FBC) REQUIREMENTS OF WIND ZONE 4, MISSILE LEVEL D AT THE DESIGN PRESSURE(S) STATED HEREIN. THE PRODUCT DETAILS CONTAINED HEREIN ARE BASED UPON SIGNED AND SEALED TEST REPORT # CTLA 1366W-4, AND ASSOCIATED LABORATORY STAMPED DRAWINGS.
2. ADEQUACY OF THE EXISTING STRUCTURAL CONCRETE / MASONRY AND 2X FRAMING AS A MAIN WIND FORCE RESISTING SYSTEM CAPABLE OF WITHSTANDING AND TRANSFERRING APPLIED PRODUCT LOADS TO THE STRUCTURE IS THE RESPONSIBILITY OF THE ENGINEER OR ARCHITECT OF RECORD.
3. IMPACT SCREEN MATERIAL: 304 STAINLESS STEEL
PANEL FRAME MATERIAL: 6005-T5 ALUMINUM ALLOY
4. A MINIMUM SEPARATION DISTANCE OF 1 INCH SHALL BE PROVIDED FOR ALL INSTALLATIONS.
5. MAXIMUM PANEL SIZE: 61.5" X 144.5"
6. PANELS MAY BE MOUNTED HORIZONTALLY WHERE APPLICABLE.
7. THE DRAWING SECTIONS HEREIN DEPICT TYPICAL CONCRETE / MASONRY AND WOOD INSTALLATION ANCHORAGE CONNECTIONS. THESE DETAILS MAY BE USED INTERCHANGEABLY AS FIELD CONDITIONS DICTATE.

INSTALLATION NOTES:

1. ONE (1) INSTALLATION ANCHOR IS REQUIRED AT EACH ANCHOR LOCATION SHOWN.
2. THE NUMBER OF INSTALLATION ANCHORS DEPICTED IS THE MINIMUM NUMBER OF ANCHORS TO BE USED FOR PRODUCT INSTALLATION.
3. NOT USED.
4. FOR INSTALLATION OF THE ALUMINUM SUBFRAME INTO WOOD FRAMING, USE #12 WOOD SCREWS OF SUFFICIENT LENGTH TO ACHIEVE 1 1/2 INCH MINIMUM EMBEDMENT. MINIMUM EDGE DISTANCE IS 3/4 INCH.
5. FOR INSTALLATION OF THE ALUMINUM SUBFRAME THROUGH 1X BUCK TO CONCRETE / MASONRY OR DIRECTLY INTO CONCRETE / MASONRY, USE 1/4 INCH ITW TAPCONS MEETING THE FOLLOWING INSTALLATION REQUIREMENTS::
 - 5.1. CONCRETE SUBSTRATE
 - 5.1.1. 1 1/2 INCH MINIMUM EMBEDMENT.
 - 5.1.2. 1 1/2 MINIMUM EDGE DISTANCE.
 - 5.2. MASONRY (CMU) SUBSTRATE
 - 5.2.1. 1 INCH MINIMUM EMBEDMENT.
 - 5.2.2. 2 MINIMUM EDGE DISTANCE.
6. FOR INSTALLATION OF THE SCREEN FRAME INTO THE ALUMINUM SUBFRAME USE #12 X 3/4 INCH HEX HEAD SMS SCREWS
7. MINIMUM EDGE DISTANCE AND EMBEDMENT EXCLUDE WALL FINISHES (INCLUDING BUT NOT LIMITED TO STUCCO, FOAM, BRICK VENEER AND SIDING).
8. FOR CONCRETE BLOCK APPLICATIONS, DO NOT INSTALL INSTALLATION ANCHORS INTO MORTAR JOINTS.
9. INSTALLATION ANCHORS SHALL BE INSTALLED IN ACCORDANCE WITH ANCHOR MANUFACTURER'S INSTALLATION INSTRUCTIONS AND ANCHORS SHALL NOT BE USED IN SUBSTRATES WITH STRENGTHS LESS THAN THE MINIMUM STRENGTH SPECIFIED BY THE ANCHOR MANUFACTURER.
10. INSTALLATION ANCHOR CAPACITIES FOR PRODUCTS HEREIN ARE BASED ON SUBSTRATE MATERIALS WITH THE FOLLOWING PROPERTIES:
 - 10.1. WOOD - MINIMUM SPECIFIC GRAVITY IS 0.42.
 - 10.2. CONCRETE - MINIMUM COMPRESSIVE STRENGTH OF 2500 PSI.
 - 10.3. MASONRY - STRENGTH CONFORMANCE TO ASTM C-90, MEDIUM WEIGHT, DENSITY > 117 PCF.

TABLE OF CONTENTS	
SHEET	SHEET DESCRIPTION
1	GENERAL AND INSTALLATION NOTES
2	ELEVATION AND ANCHOR LAYOUTS
3	VERTICAL & HORIZONTAL SECTIONS
4	VERTICAL & HORIZONTAL SECTIONS
5	BILL OF MATERIALS & COMPONENTS

DESIGN PRESSURE RATING (PSF)	IMPACT RATING
+80.0/-80.0	WIND ZONE 4 MISSILE LEVEL D

PROJECT #415-0207

REV	DESCRIPTION	DATE	BY
A	UPDATED TO 5TH ED. (2014) FBC	5/6/15	RJA

1661 GLENLAKE AVE.
ITASCA, IL 60143

DATE: 12/09/12
DRAWING NO: QMI0001
SHEET: 1 OF 5

QMI

STORMSAFE SCREEN - FIXED IMPACT SCREEN - NON-HVHZ
GENERAL AND INSTALLATION NOTES

DRAWN BY: RJA
SCALE: N.T.S.
REV: A

PTC PRODUCT DESIGN GROUP, LLC
PO BOX 520778
LONG BEACH, CA 90801-0778
Phone: 321.690.1788
Fax: 321.690.1789
Email: info@ptc-corp.com

PDC

Robert J. Amoruso, P.E.
Florida P.E. No. 49752

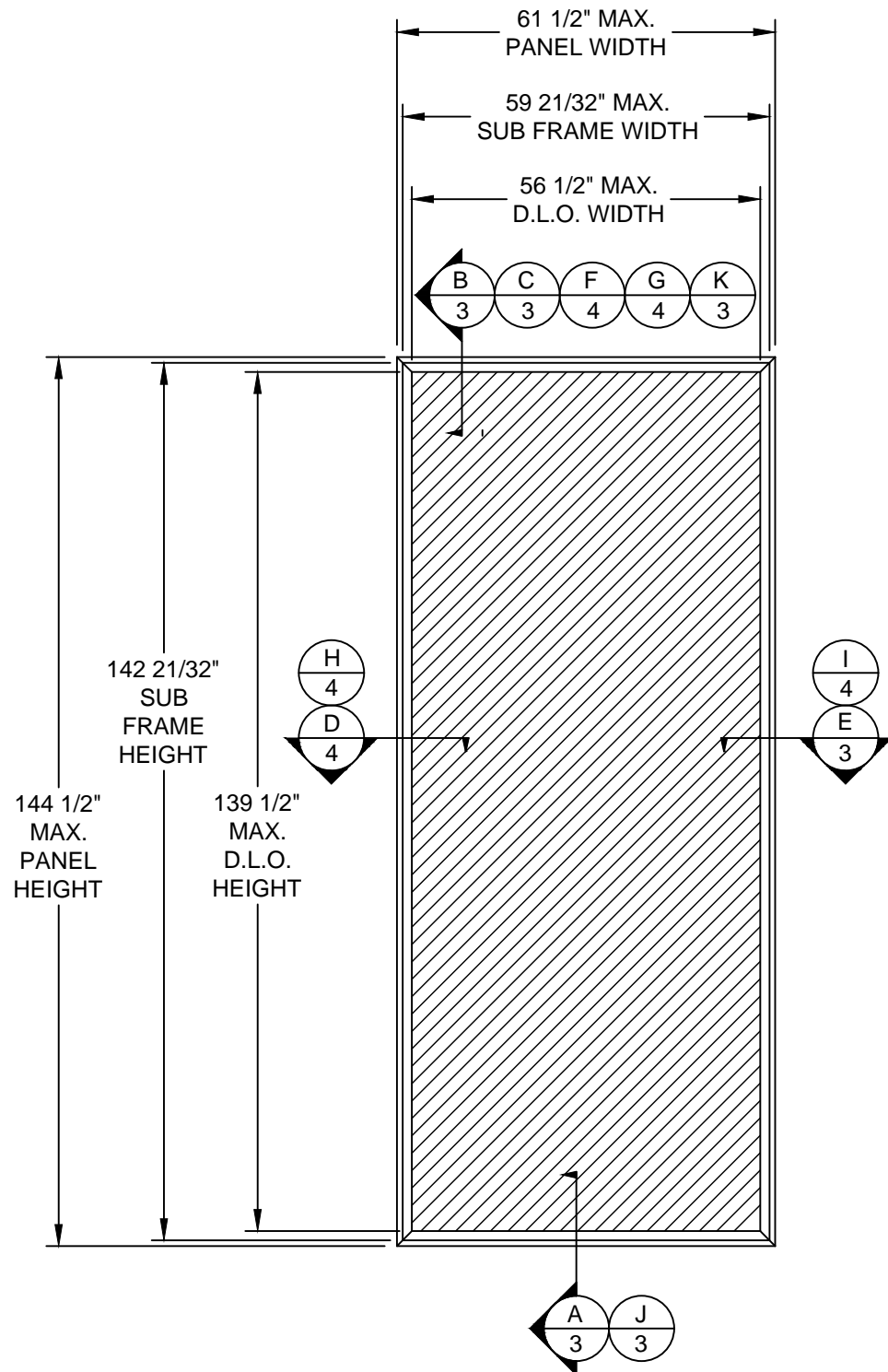

ELEVATION
EXTERIOR VIEW

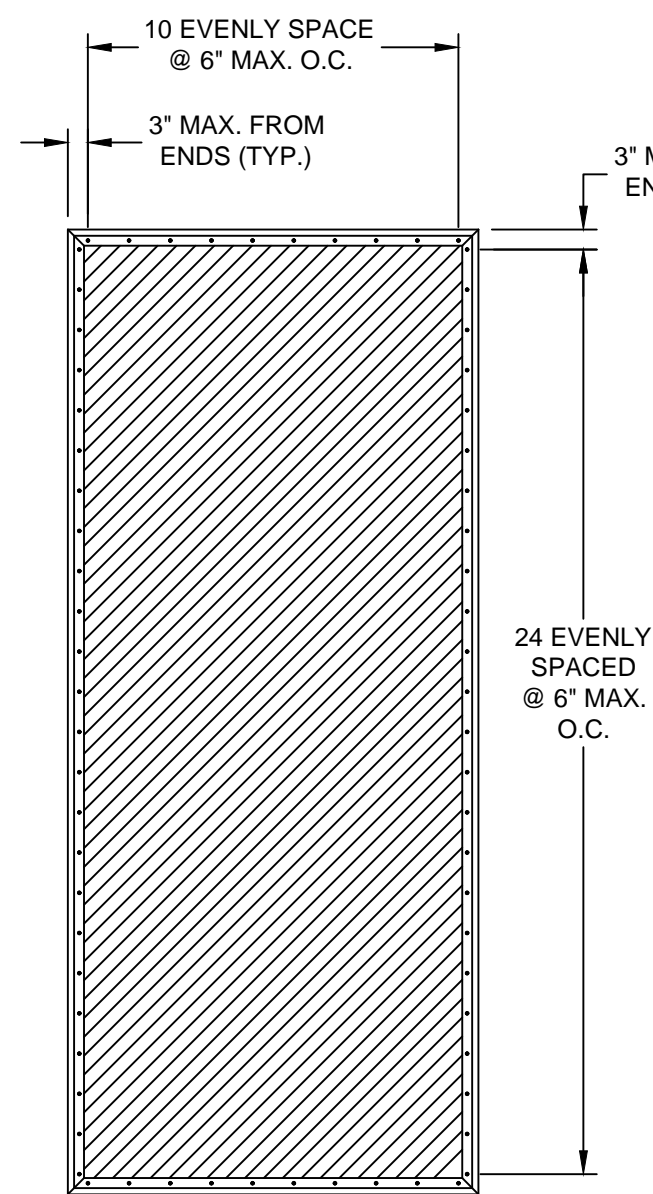

ANCHOR LAYOUT
SCREEN FRAME TO
ALUMINUM TUBING

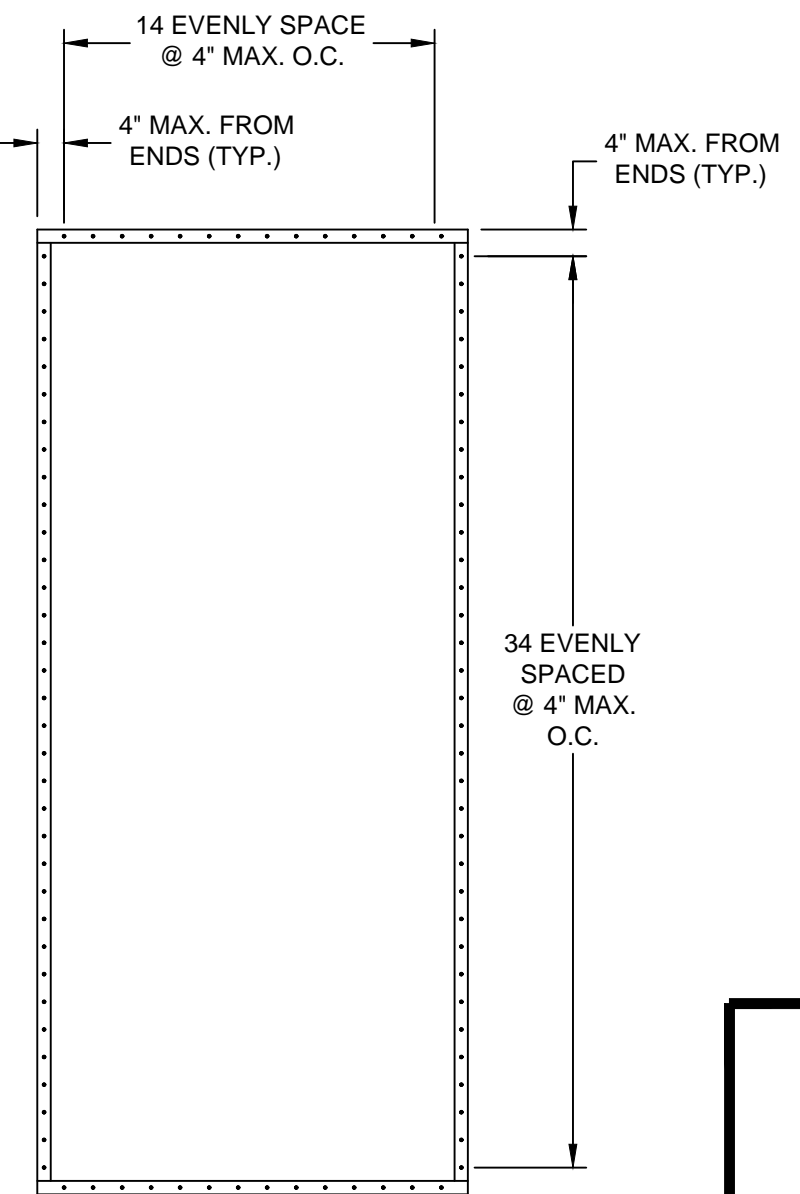

ANCHOR LAYOUT
ALUMINUM TUBE OR SCREEN FRAME
TO SUBSTRATE

PROJECT #415-0207

1661 GLENLAKE AVE.
ITASCA, IL 60143

QMI

TITLE: STORMSAFE SCREEN - FIXED IMPACT SCREEN - NON-HVHZ
ELEVATION & ANCHOR LAYOUTS

PREPARED BY: RJA
SCALE: N.T.S.
DATE: 12/09/12
DRAWING NO: QMI0001
SHEET: 2 OF 5

REV: A

REV: A
DESCRIPTION
DATE
BY

5/6/15
RJA

UPDATED TO 5TH
ED. (2014) FBC

PTC

PTC PRODUCT DESIGN GROUP, LLC
PO BOX 520775
LONGWOOD, FLORIDA 32752
Phone: 321.690.1788
Fax: 321.690.1788
Email: info@ptc-corp.com

Robert J. Amoruso, P.E.
Florida P.E. No. 49752

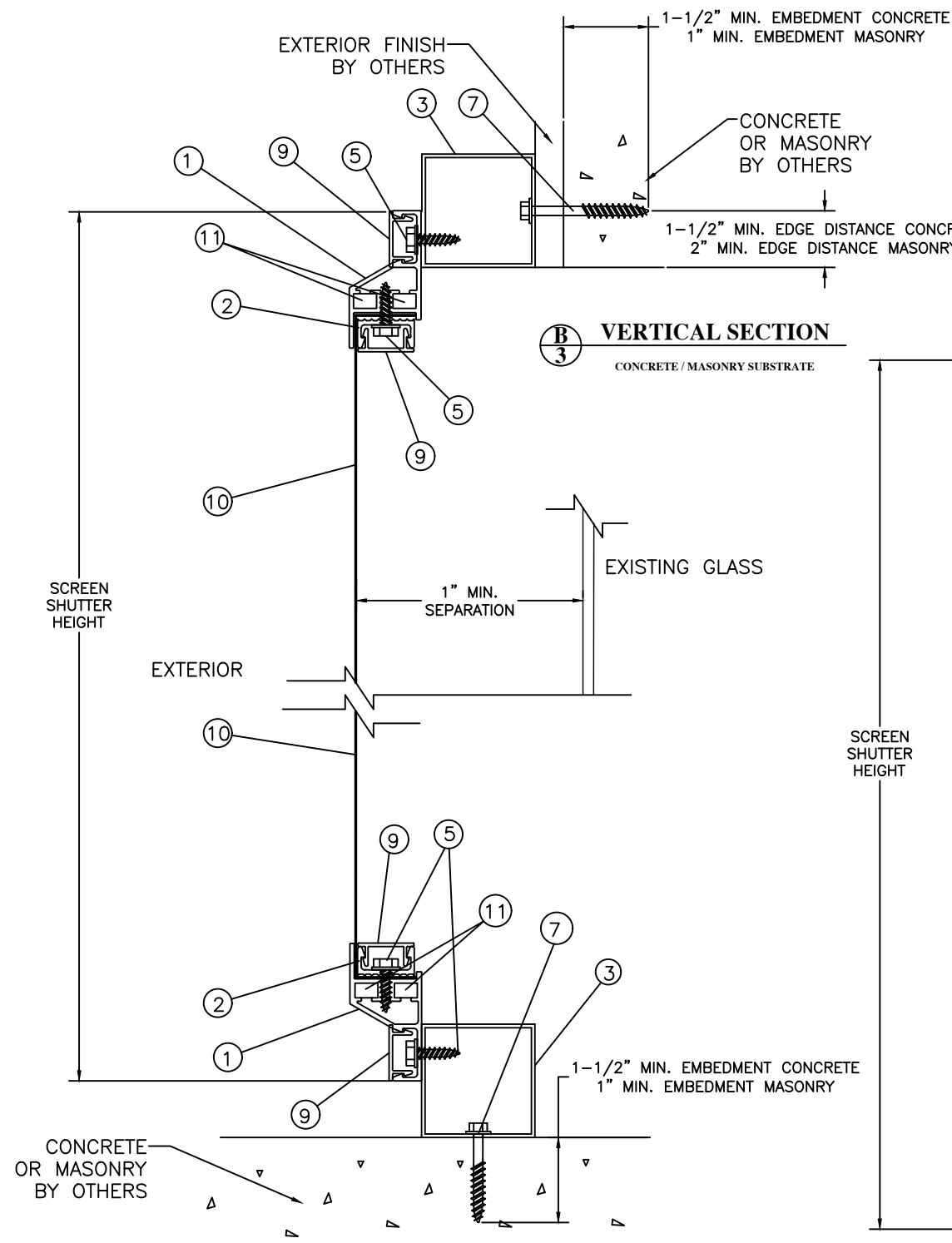

B
3
VERTICAL SECTION
CONCRETE / MASONRY SUBSTRATE

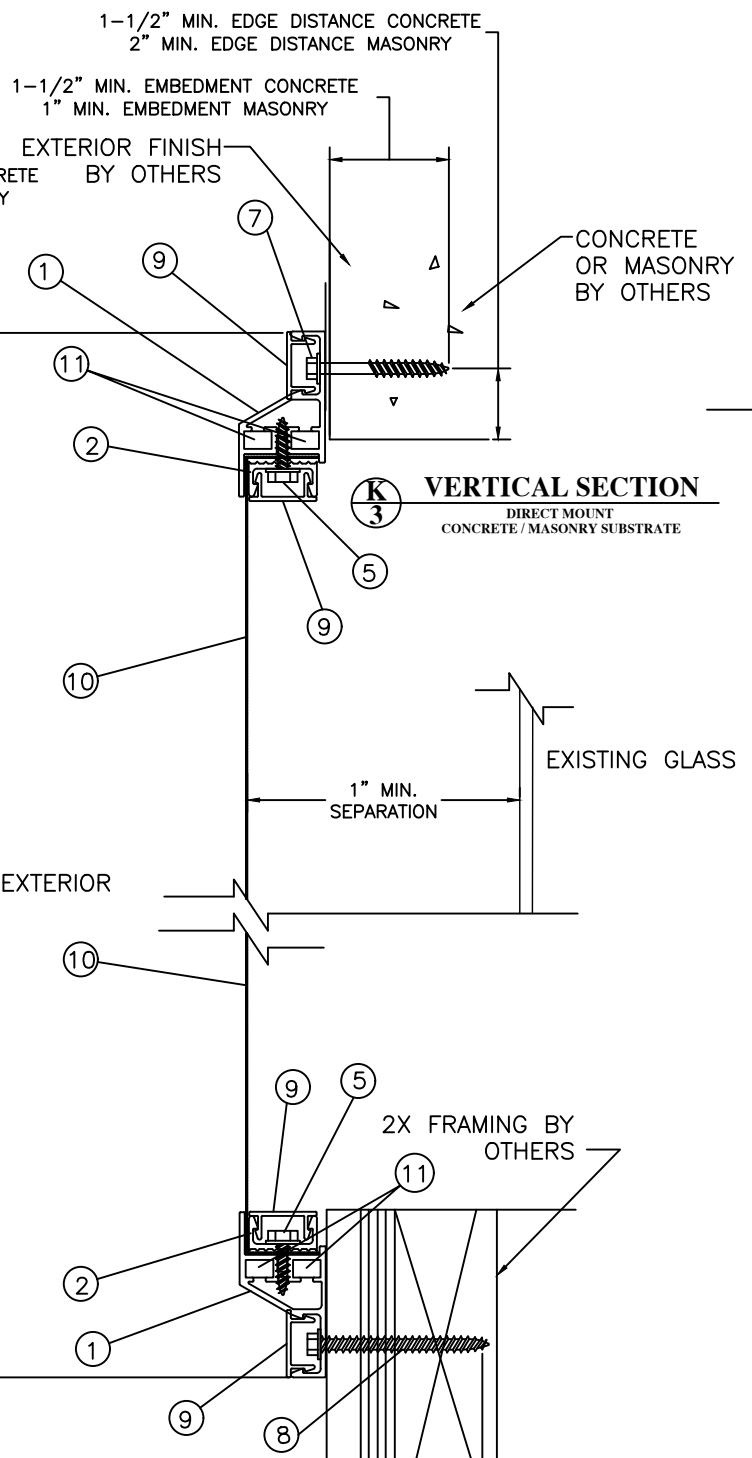

K
3
VERTICAL SECTION
DIRECT MOUNT
CONCRETE / MASONRY SUBSTRATE

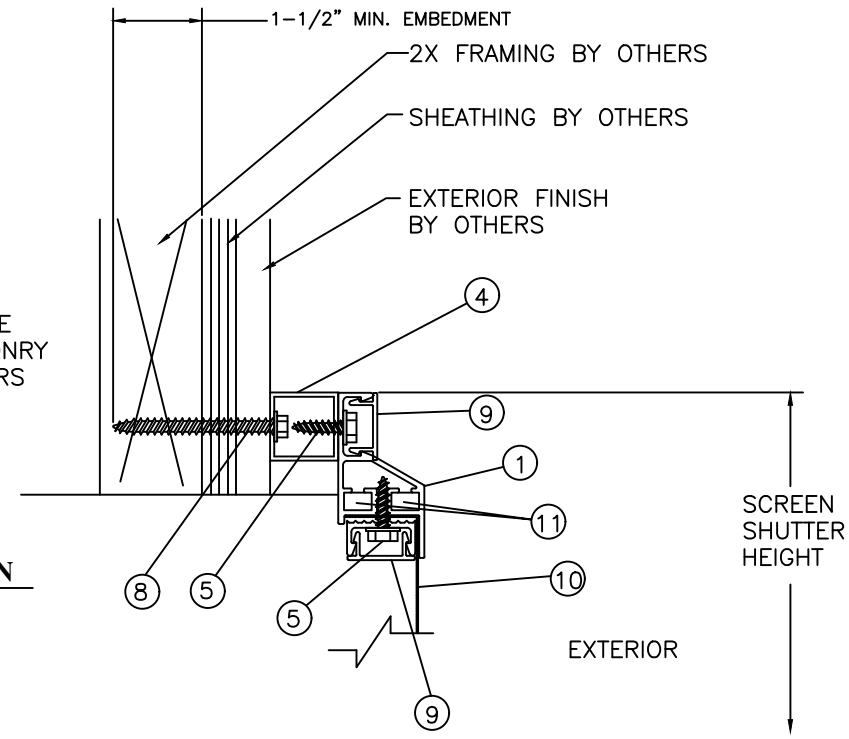

C
3
VERTICAL SECTION
SHOWN IN 2X WOOD FRAMING

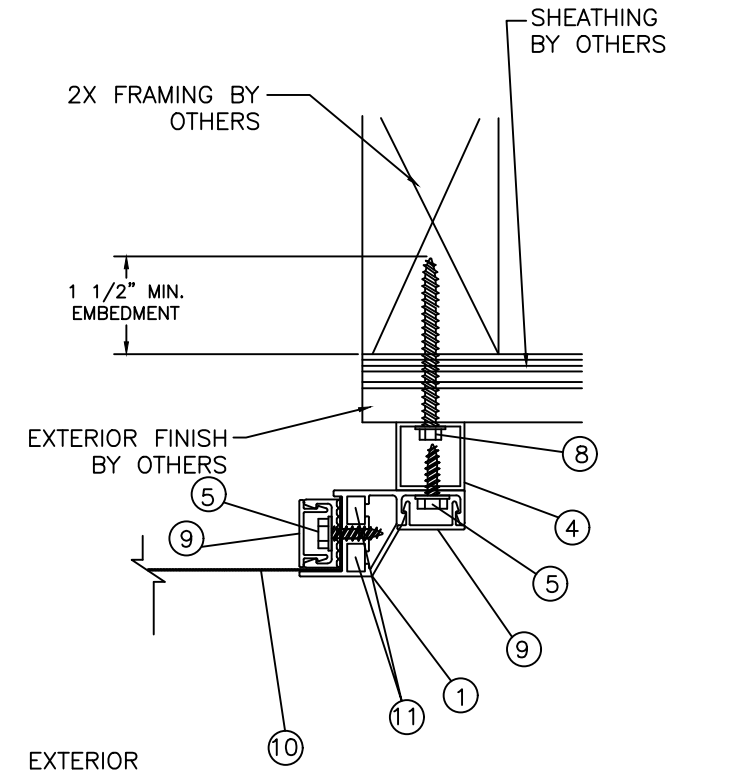

E
3
HORIZONTAL SECTION
SHOWN IN 2X WOOD FRAMING
2X FRAMING BY OTHERS

- NOTES:
- 2" ALUMINUM TUBE HAS A 1" MIN. EDGE DISTANCE WITH NO SETBACK FROM EDGE OF CONCRETE/MASONRY AT INSTALLATION.
 - 1" ALUMINUM TUBE HAS A 1" MIN. EDGE DISTANCE WITH 1/2" SETBACK FROM EDGE OF CONCRETE/MASONRY AT INSTALLATION.

A
3
VERTICAL SECTION
CONCRETE / MASONRY SUBSTRATE

J
3
VERTICAL SECTION
DIRECT MOUNT
2X WOOD FRAME SUBSTRATE

PROJECT #415-0207

1661 GLENLAKE AVE.
ITASCA, IL 60143

QMI
TITLE: STORMSAFE SCREEN - FIXED IMPACT SCREEN - NON-HVHZ
VERTICAL & HORIZONTAL SECTIONS

DATE:	12/09/12	DATE:	5/6/15	DATE:	
DRAWN BY:	RJA	DESCRIPTION:	UPDATED TO 5TH ED. (2014) FBC	REV:	
SCALE:	N.T.S.	DRAWING NO.:	QMI0001	BY:	RJA
REV:	A	SHEET:	3 OF 5	DATE:	

Robert J. Amoruso, P.E.
Florida P.E. No. 49752

PTC
PREPARED BY:
PTC PRODUCT DESIGN GROUP, LLC
PO BOX 520775
LONGWOOD, FLORIDA 32752
Phone: 321.690.1788
Fax: 321.690.1789
Email: info@ptc-corp.com

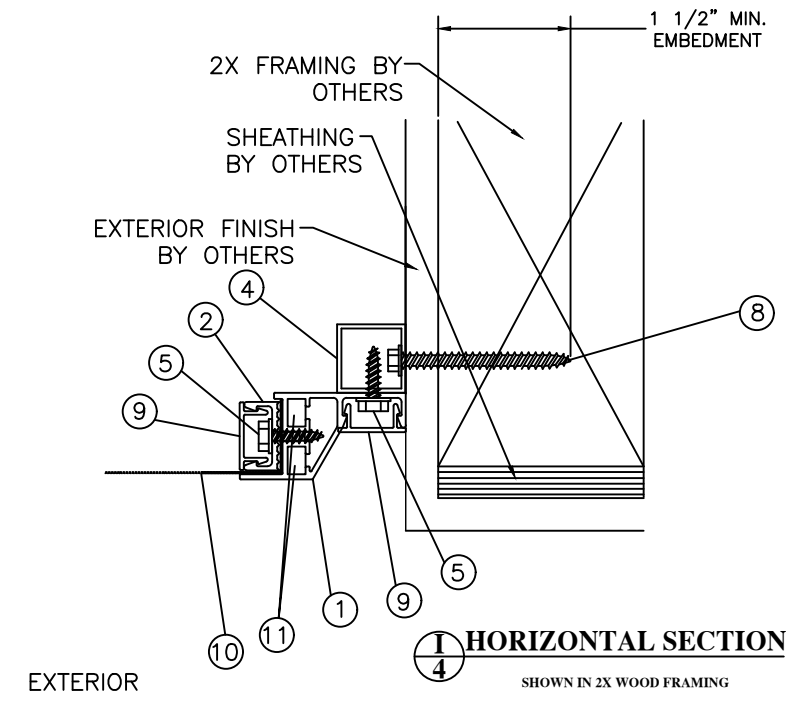
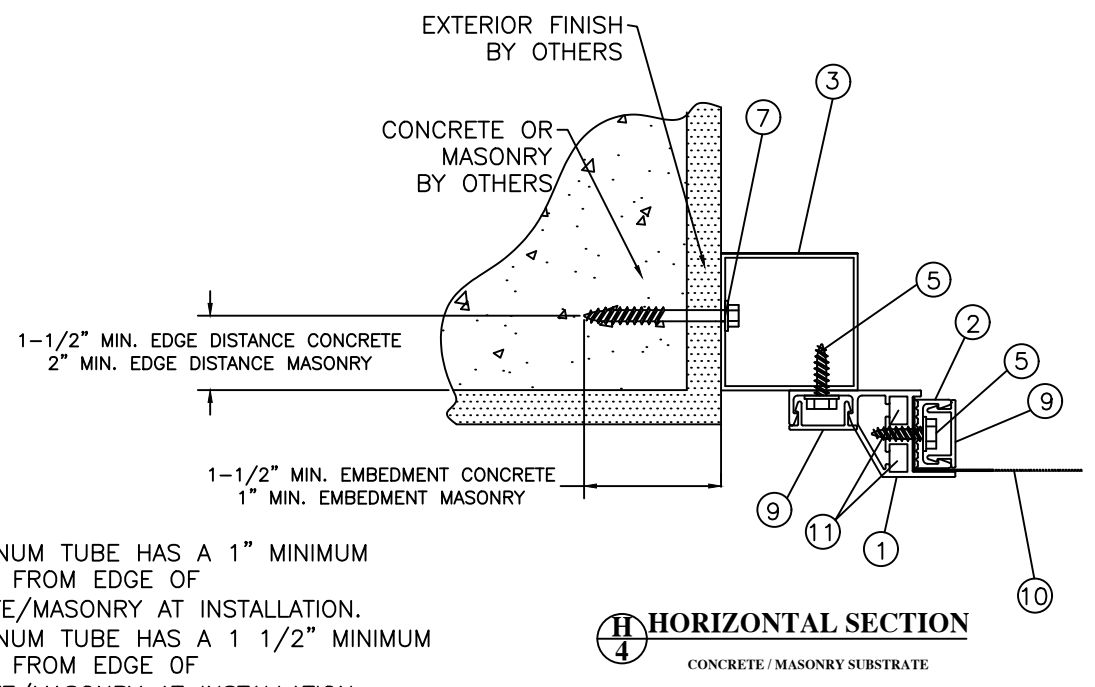
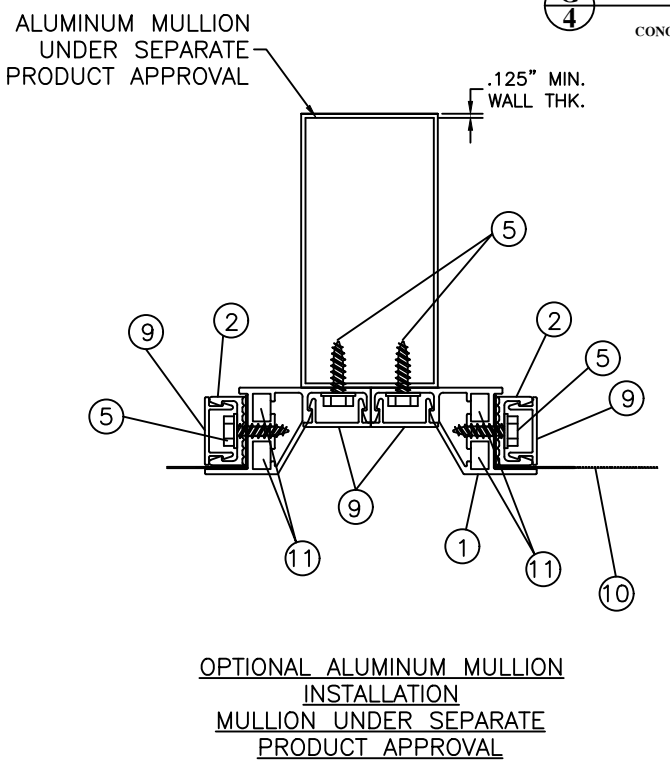
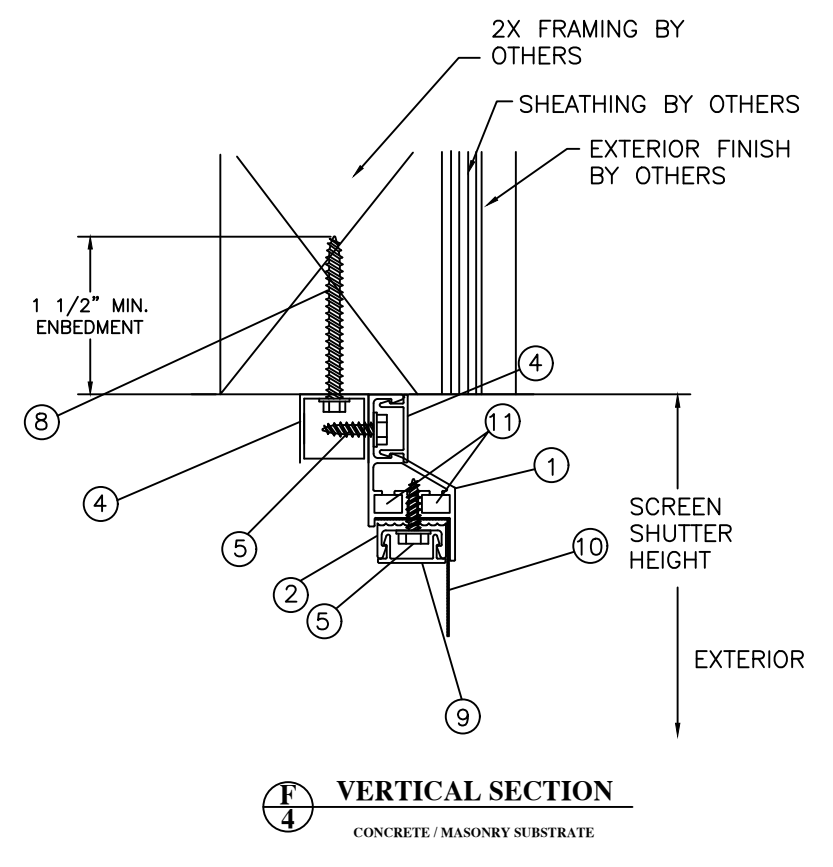
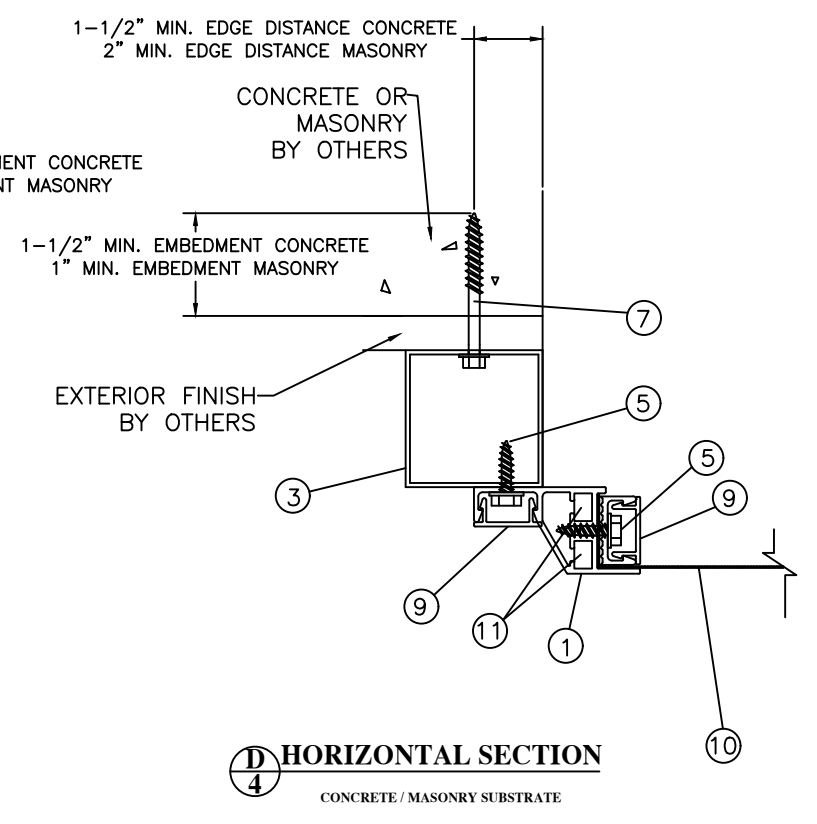
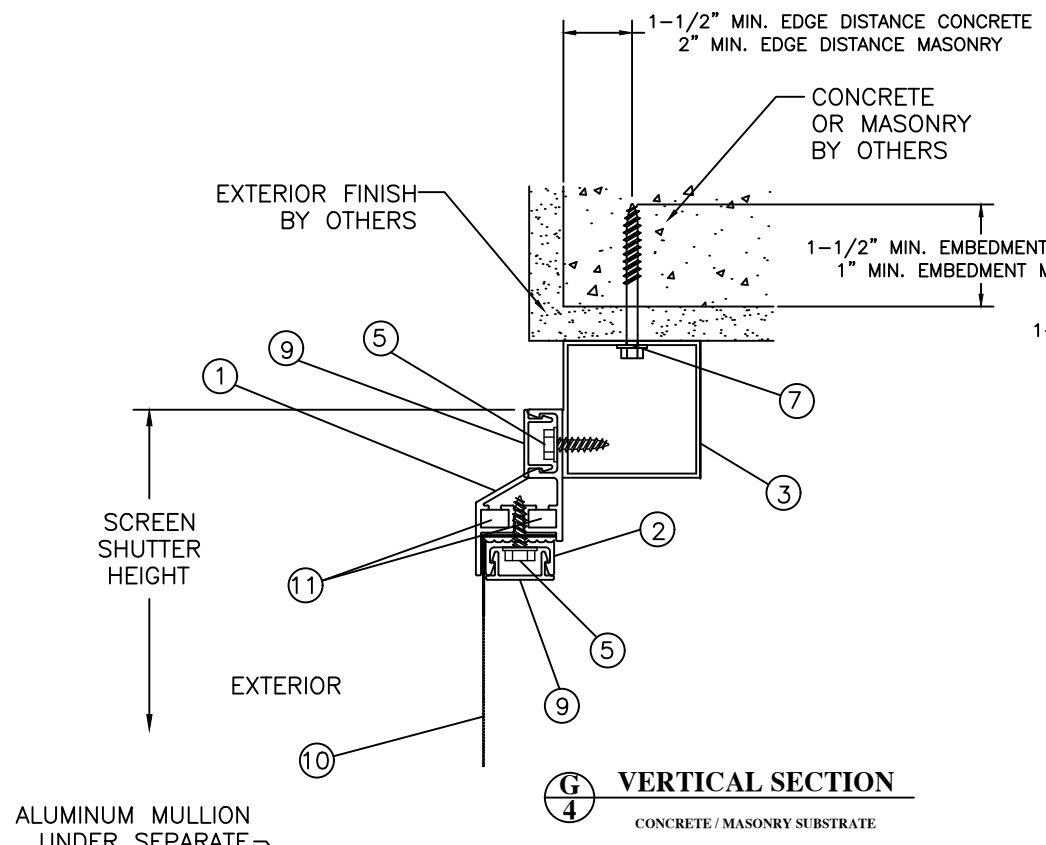

- NOTES:
- 2" ALUMINUM TUBE HAS A 1" MINIMUM SETBACK FROM EDGE OF CONCRETE/MASONRY AT INSTALLATION.
 - 1" ALUMINUM TUBE HAS A 1 1/2" MINIMUM SETBACK FROM EDGE OF CONCRETE/MASONRY AT INSTALLATION.

PROJECT #415-0207

1661 GLENLAKE AVE.
ITASCA, IL 60143

QMI

TITLE: STORMSAFE SCREEN - FIXED IMPACT SCREEN - NON-HVHZ
VERTICAL & HORIZONTAL SECTIONS

PREPARED BY: RJA
DATE: 12/09/12
DRAWING NO: QMI0001
SCALE: N.T.S.
REV: A
SHEET: 4 OF 5

PTC PRODUCT DESIGN GROUP, LLC
PO BOX 520775
LONGWOOD, FLORIDA 32752
Phone: 321.690.1786
Fax: 321.690.1785
Email: info@ptc-corp.com

REV	DESCRIPTION	DATE	BY
A	UPDATED TO 5TH ED. (2014) FBC	5/6/15	RJA

Robert J. Amoruso, P.E.
Florida P.E. No. 49752

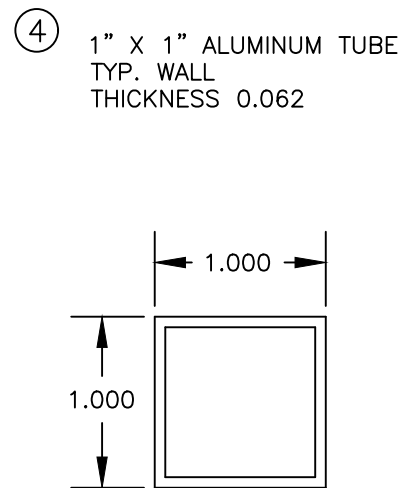
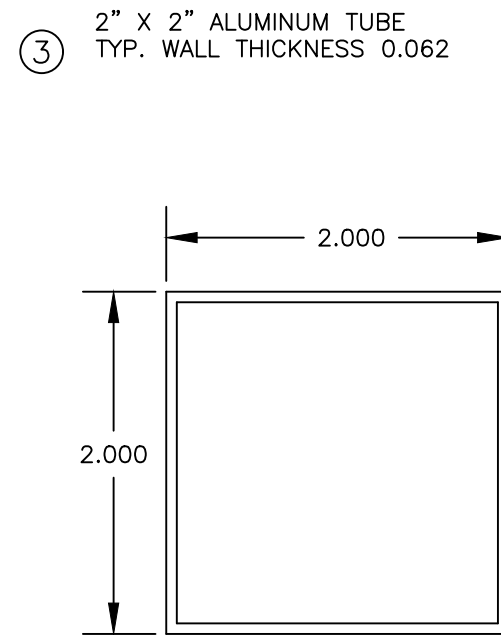
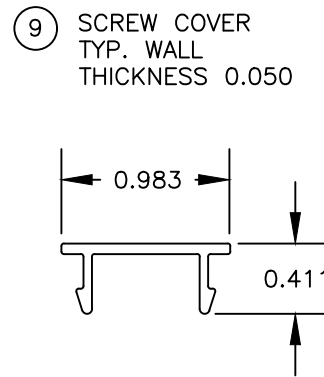
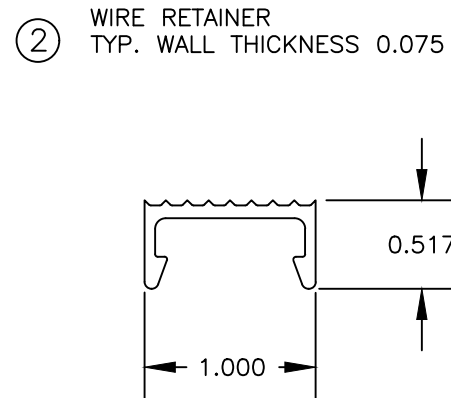
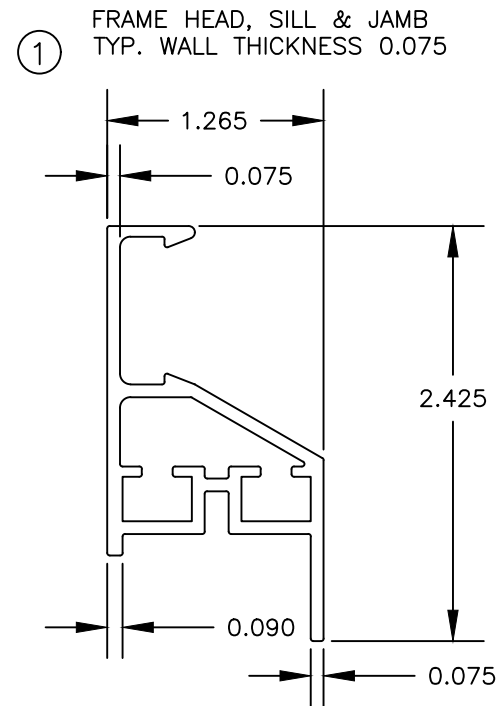

BILL OF MATERIALS	
ITEM #	DESCRIPTION
1	FRAME HEAD, SILL & JAMB 6005-T5 ALUMINUM
2	WIRE RETAINER 6005-T5 ALUMINUM
3	2" X 2" X 1/16" ALUMINUM TUBE 6063-T5
4	1" X 1" 1/16" ALUMINUM TUBE 6063-T5
5	#12-14 X 3/4" HEX HEAD TEK SCREW
6	NOT USED
7	1/4" HH I.T.W. TAPCON
8	NO. 12 HH SELF TAPPING SCREW (SHOWN) OR WOOD SCREW
9	SCREW COVER
10	MESH 12X12 SCREEN SS 304 THREAD 0.028" OR 0.032" THICK
11	CORNER KEY 2" X 2" X 0.40" X 1/4"

PROJECT #415-0207

1661 GLENLAKE AVE.
ITASCA, IL 60143

TITLE: STORMSAFE SCREEN - FIXED IMPACT SCREEN - NON-HVHZ
COMPONENTS & BILL OF MATERIALS

PREPARED BY:	RJA	DATE:	12/09/12
DRAWN BY:	RJA	DRAWING NO.:	QMI0001
SCALE:	N.T.S.	REV:	A
SHEET:	5 OF 5	DESCRIPTION	REV
		DATE	BY
		5/6/15	RJA

Robert J. Amoruso, P.E.
Florida P.E. No. 49752